



**3 GHz SMA LATCHING S.P.4 T. SWITCH**

OPTIONS : INDICATOR /SELF CUT-OFF / TTL DRIVE /SUPP.DIODES

**R F CHARACTERISTICS**

NUMBER OF WAYS : 4  
 FREQUENCY RANGE : 0 - 3 GHz  
 IMPEDANCE : 50 Ohms

FREQUENCY (GHz)	0 - 3
V.S.W.R <=	1.20
INSERT. LOSS <=	0.20 dB
ISOLATION >=	80 dB
AVER. POWER (*)	240 W

**ELECTRICAL CHARACTERISTICS**

ACTUATOR : LATCHING  
 NOMINAL CURRENT AT 25° C (±10%) : 320 mA / RESET : 1280 mA  
 ACTUATOR VOLTAGE (Vcc) : 12V (10.2 to 13V) / NEGATIVE COMMON  
 TERMINALS : 25 pins D-SUB male connector  
 INDICATOR RATING : 1 W / 30 V / 100 mA  
 SELF CUT-OFF TIME : 40 ms < CT < 120 ms  
 TTL INPUTS (E) - High level : 2.2 to 5.5V / 800µA at 5V  
 - Low level : 0 to 0.8V / 20µA at 0.8V

**MECHANICAL CHARACTERISTICS**

CONNECTORS : SMA female per MIL C 39012  
 LIFE : 5.000.000 cycles per position  
 SWITCHING TIME (nominal voltage;25° C) : < 15 ms  
 CONSTRUCTION : splashproof  
 WEIGHT : < 220 g

**ENVIRONMENTAL CHARACTERISTICS**

OPERATING TEMPERATURE RANGE (°C) : -40 , +85  
 STORAGE TEMPERATURE RANGE (°C) : -55 , +85

(\* : average power at 25° C per RF path)

4112-9212 This information is given as an indication. In the continual goal to improve our products, we reserve the right to make any modifications judged necessary

**DRAWING**

General tolerance: ± 0,5 mm

**R573 352.425**

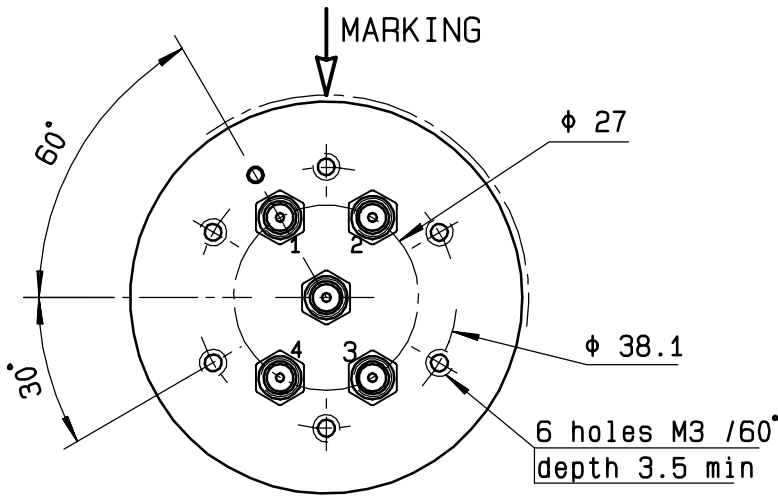

TTL input	RF continuity	Ind.
RESET = 1	All ports open	--
E1 = 1	IN ↔ 1	D.E
E2 = 1	IN ↔ 2	D.F
E3 = 1	IN ↔ 3	D.G
E4 = 1	IN ↔ 4	D.H

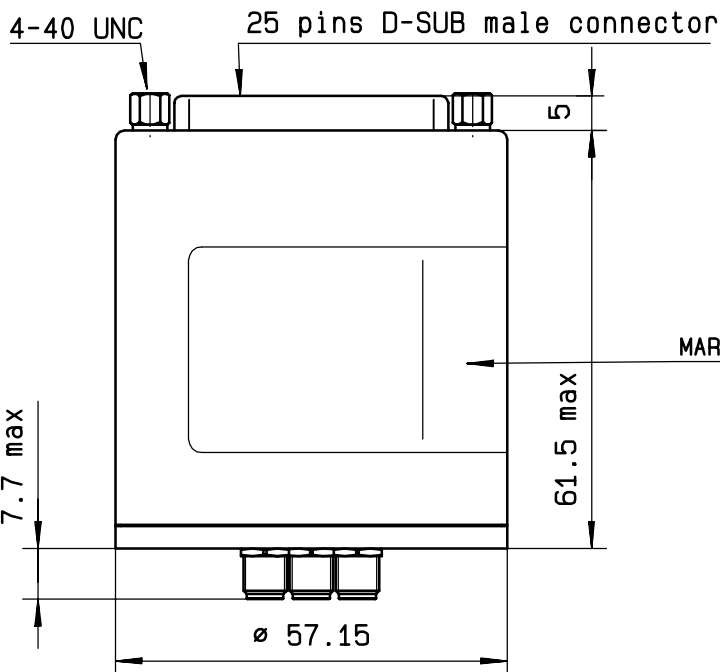

MARKING TOP VIEW (TERMINALS)

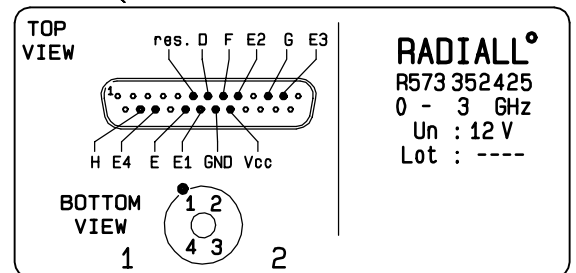

**RADIALL<sup>o</sup>**  
R573 352425  
0 - 3 GHz  
Un : 12 V  
Lot : ----

**SCHEMATIC DIAGRAM**

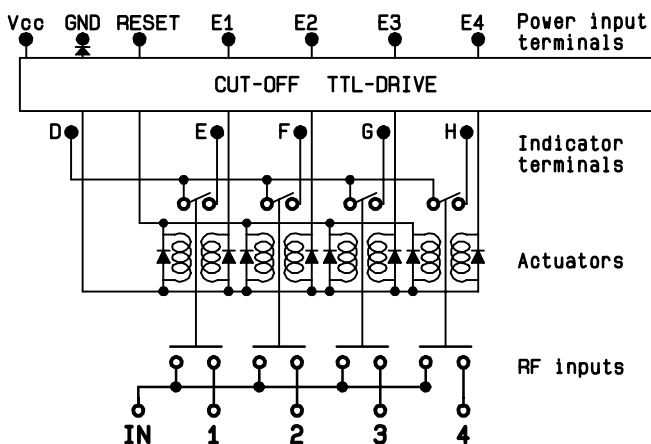

This information is given as an indication. In the continual goal to improve our products, we reserve the right to make any modifications judged necessary

4113-9212